

SLIDEKAMERA

NEXT LEVEL OF FILMMAKING



ATLAS™ MODULAR

MODULAR SLIDER

User Manual

pdf version of the manual available for download: www.slidekamera.com



6/2016

TIP

On the margins you will find information, which complement the contents of the manual.

They are not essential for the correct operation of the device, but you might find them useful.

Before you start your work with the **ATLAS MODULAR** slider we strongly recommend to read the manual carefully.

Please note that using the adapter in a manner inconsistent with the instructions, any unauthorized repair attempts or any kind of modification of the device can cause a damage the manufacturer is not responsible for.

Table of contents

1. Description of the ATLAS MODULAR slider	3
2. Construction of the ATLAS MODULAR slider	3
2.1. Elements of the ATLAS MODULAR slider	3
2.2. Cart elements	4
3. Mounting the elements of the ATLAS MODULAR system	5
3.1. Connecting the sections	5
3.2. The central port of the cart	6
3.3. Motion end blocks	7
3.4. Adjustable feet	7
3.5. Centering adapters	7
3.6. ATLAS MODULAR drive	8
4. Mounting additional accessories	9
4.1. Quick release adapter	9
4.2. V-mount batteries	10
5. Usage of ATLAS MODULAR slider	11
5.1. Manual work	11
5.2. Working with ATLAS MODULAR drive	12
5.3. The ATLAS MODULAR drive and a controlled head	13
6. Technical specification	14
7. Terms of warranty	15

Slidekamera®
High Engineering Technology CNC s.c.
Sebastian Pawelec Karol Mikulski
Głina 45
82-522 Sadlinki
VAT Identification Number:
581-188-33-32

Slidekamera Office
80-175 Gdańsk (Poland)
ul. Kartuska 386
tel./fax (+48) 58 710 41 04
e-mail: biuro@slidekamera.com
www.slidekamera.com

1. Description of the ATLAS MODULAR slider

The **ATLAS MODULAR** modular slider was designed for work with heavy cameras (such as CANON C500, SONY F55, ARRI ALEXA).

ATLAS MODULAR is a modular system. Its construction allows working with various configurations of length and location, as well as attaching of additional accessories.

The drive, used in the **ATLAS MODULAR** slider, is compatible with the motion control system, manufactured by **SLIDEKAMERA**. Thanks to this the motions of the slider and the rotating head (e.g. **BULL HEAD**) can be simultaneously controlled by one controlling device or mobile application.

2. Construction of the ATLAS MODULAR slider

2.1. Elements of the ATLAS MODULAR slider

The **ATLAS MODULAR** slider was designed in such a way that every user can adapt its configuration to its own needs. Below you will find the construction of a standard set, consisting of 2 sections and basic accessories.

- [1] slider cart
- [2] 0,8 m rail
- [3] 1,2 m rail
- [4] adjustable feet
- [5] motion end blocks

NOTE
The contents of the purchased set may differ from the one, presented below.



2.2. Cart elements

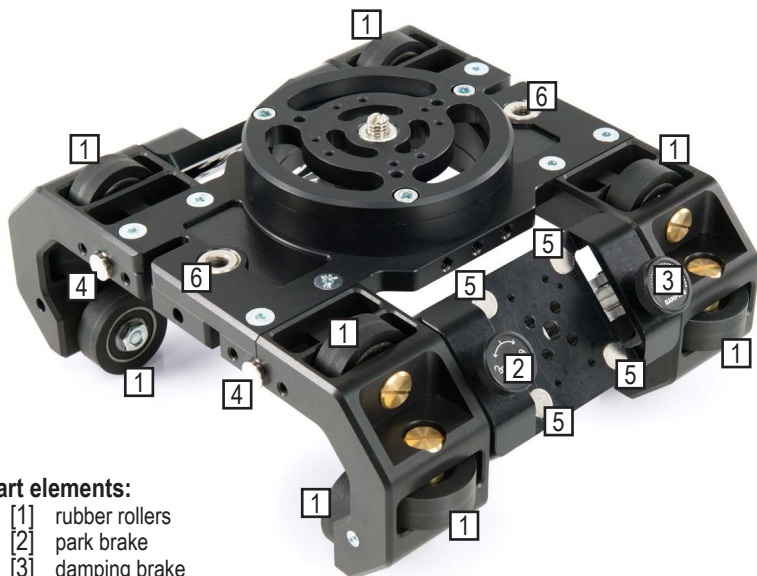

Cart elements:

- [1] rubber rollers
- [2] park brake
- [3] damping brake
- [4] magnetic bumpers
- [5] magnetic holders
- [6] 3/8" thread mounting holes for accessories

The **ATLAS MODULAR** slider's cart is equipped in 12 rollers, made of specially assorted hardened rubber [1]. Thanks to the proper location of the rollers the slider can move in a horizontal, inverse, vertical and slanted position.

While working with the slider you can fix its position using the park brake [2]. It is meant only for blocking the position of the dolly and has to be released before commencing work.

The damping brake [3] generates resistance while moving the slider. It helps to achieve a precise motion of the slider's cart, enabling the operator to acquire a smooth motion.

The slider's cart and end blocks have integrated magnetic bumpers [4], which function as brakes when the cart with the camera is reaching the end of the slider. The magnets gently brake the cart, informing the operator of the approaching end of ride. Thanks to this the user can focus on achieving the best shot and not get distracted with controlling the range of the slider's motion.

Additional accessories can be mounted to the slider's dolly with magnetic holders [5]. Some **SLIDEKAMERA** devices are equipped with compatible magnetic holders (e.g. wireless **SLIDE LINK** adapter), some require a special adapter.

The accessories may be also mounted to the slider's dolly by screws. Proper holes [6] are located on the dolly's frame.

NOTE

Do not treat the damping brake as a protection from the dolly's self-motion, e.g. while working in a slanted position!

3. Mounting the elements of the ATLAS MODULAR system

3.1. Connecting the sections

The ATLAS MODULAR allows to mount additional sections in an easy way to form a 4m, 8m or longer slider, if necessary. Assembly and disassembly does not require tools.

Before connecting the sections put them on an even and flat surface so that you don't damage the mounting screws while screwing them in a slanted position.

Match the sections.

Note: each section has a “left” and “right” side – one side has centering pins [1] and mounting screws [2], the other one – pin holes [3] and screw holes [4].

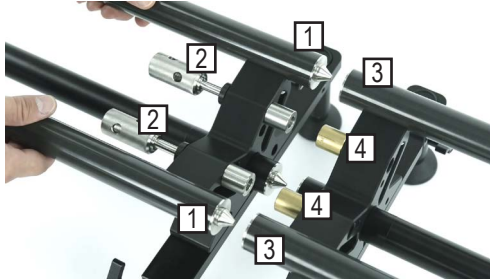

Tighten the mounting screws.



It is easier to assemble the sections with a special key [1], which allows to tighten the screws with more force.



You will find the key [1] in a magnetic holder in the slider's cart. Please remember to put it in the same place after usage.



TIP

In some sets the ATLAS MODULAR system can be delivered partially assembled, however the knowledge of the assembly ways can become useful when changing the configuration of the device or in case of non-standard way of transporting.

3.2. The central port of the cart

Flat mounting plate 3/8"

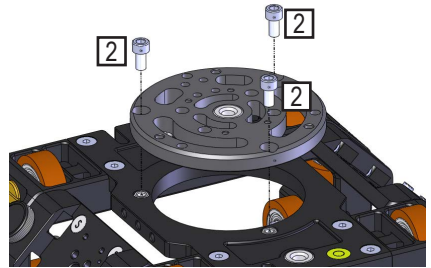

TIP

Apart from the 3/8" screw hole, the plate has M4 screw mounting holes compatible with Manfrotto adapters, which ensure a secure and stable mounting of adapters, such as **SLIDEKAMERA AKC-3**.

Heads, which are fitted with 3/8" screws have to be mounted on a flat mounting disc [1], equipped with 3/8" screw socket. Its compact structure allows to lower the center of gravity of devices, mounted on the dolly and minimize the occurrence of unwanted vibrations.

Tighten the disc to the cart's frame with 3 Allen screws [2], attached to the set.

Adapter for heads with 75/100mm half-balls

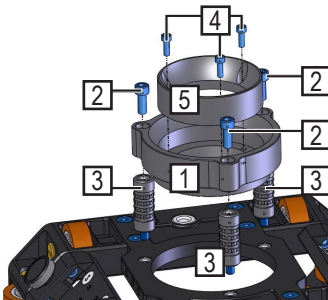
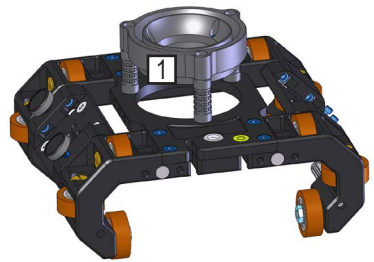
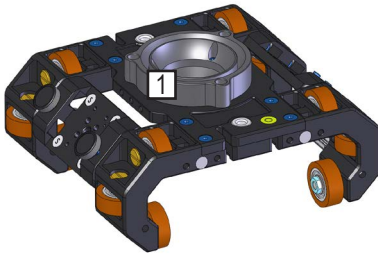

For mounting heads with 75/100mm half-balls use a special aluminum bowl [1].

- Mount it to the cart's frame with 3 Allen screws [2]. If the head has a long mounting screw and more space under the adapter is needed, then use the provided distances [3]. First attach the distances, then the adapter.
- If using a 75mm head, tighten a reduction bush [5] to the adapter with 3 Allen screws [4].

3.3. Motion end blocks

To secure the slider's dolly put the motion end blocks [1] in the slider's end sections.

- Fit the end blocks into appropriate centering holes [2].
- Tighten them with knobs [3], located on the outer side of the end blocks.

The end blocks also have clamps for mounting the timing belt of the slider's drive [4].

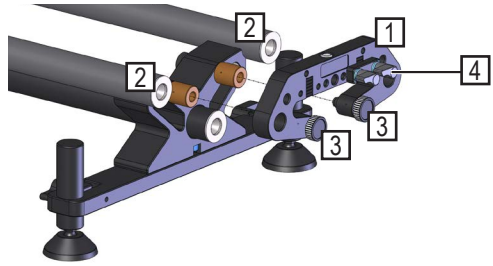

3.4. Adjustable feet

Each section has 4 regulated feet which adjust to the ground. When the set is standing on the ground, it can be quickly leveled.

- attach the foot's mounting element [2] with 4 Allen screws [1] to the slider's rail's end port [3]
- place the regulated feet [4] in the sockets
- adjust their height and tighten the clamps [5]

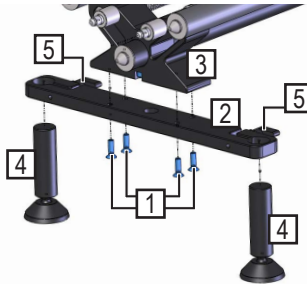

TIP

The feet are necessary for the proper functioning of the slider, when it is standing directly on the ground. They can be removed to make work easier when the slider is mounted, e.g. on a tripod.

3.5. Centering adapters

The producer provided centering adapters for correct and quick mounting of the slider to the tripods. The adapters are fit for tripod sockets with a diameter of 75 and 100mm. Each section has one 75/100mm centering adapter.

- With 4 Allen screws [1] tighten the centering adapter [2] to the chosen port of the slider's rail [3],
- if the slider consists of one section only, tighten the adapter to the middle port,
- if the slider consists of several sections, choose the mounting points carefully to attain stable support,
- note that each section should be supported at least in one point,
- to mount the slider on the tripod place the adapter underneath the tripod's socket; tighten the adapter as an ordinary head; use a universal 3/8" screw.

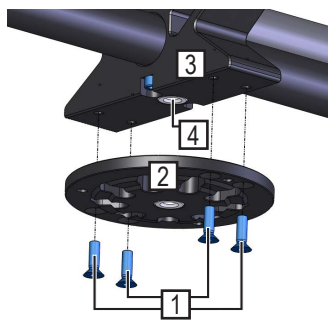

TIP

As the feet and the slider's rails' ports are equipped with 3/8" sockets [4] it is possible to mount the tripod directly to the port. Such installation is not recommended for tripods with bowls for mounting 75/100mm half-balls due to the lack of precision of mounting and a potential lack of connection stability.

3.6. ATLAS MODULAR drive

The drive of ATLAS MODULAR was designed especially for work with the ATLAS MODULAR slider, that is why it is light and precise and very fast.

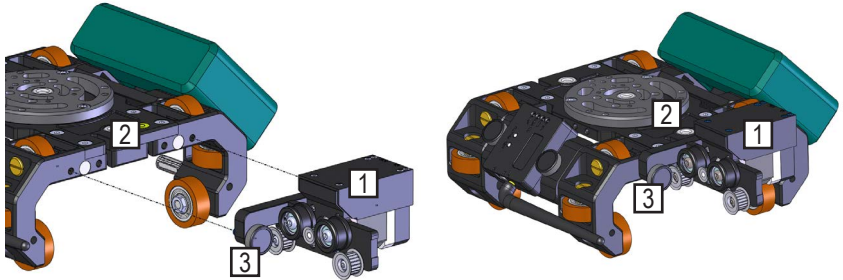

Assemble the ATLAS MODULAR drive:

- attach the drive [1] to the cart's frame [2],
- tighten with knobs [3].

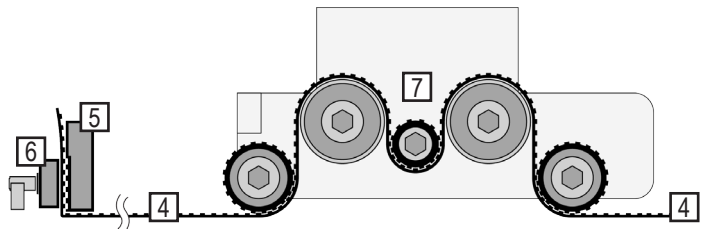

TIP

When mounting the timing belt note, whether the clamp is on the correct side of the slider – the same one where the drive's gear wheel is. If necessary, place the clamp symmetrically on the other side of the stop [5].

The drive can be also mounted on the other side of the cart or the whole cart can be reversed with the drive.

Fit the timing belt [4] into the correctly fitted drive:

- place its end in the clamp on the motion end block [5] and tighten the clamps [6],
- conduct the belt through the drive's wheels [7],
- place the second end of the belt analogically on the second motion end block,
- stretch the timing belt,
- holding the stretched belt tighten the clamp on the other motion end block.

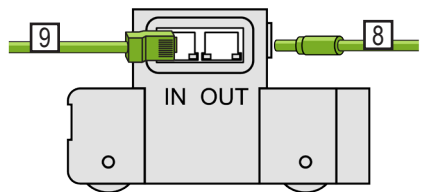

TIP

Detailed information on connecting and using the controller can be found in the instruction manual.

Connect the cables to the drive:

- connect the power supply [8] (battery or power supply unit) to the DC socket on the side of the device,
- connect a cable [9], connecting the drive to your controller, to the IN input on the front of the drive.

4. Mounting additional accessories

There are many additional accessories for the **ATLAS MODULAR** system, which expand its possibilities. That is why there are standard screw holes on particular elements of the system, as well as magnetic holders, which allow fast installation of devices with compatible holders.

4.1. Quick release adapter

For the safety of the equipment, speed of usage and facilitation of transport **SLIDEKAMERA** suggests the usage of an adapter for fast head mounting. Using this adapter prevents loosening of the head while using and damaging the equipment while mounting (which can happen if the head is tightened in an incorrect way).

To mount the adapter:

- fix the mounting plate [2] on the slider's dolly [1] (section 3.2, p. 6),
- attach the base of the adapter [3] to the mounting plate [2] with 4 M4 screws [4], included in the set,
- screw the adapter's plate [5] to the head [6],
- insert the plate into the adapter,
- tighten the clamp screw [7].

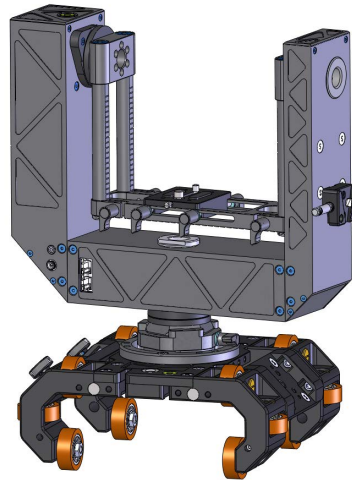
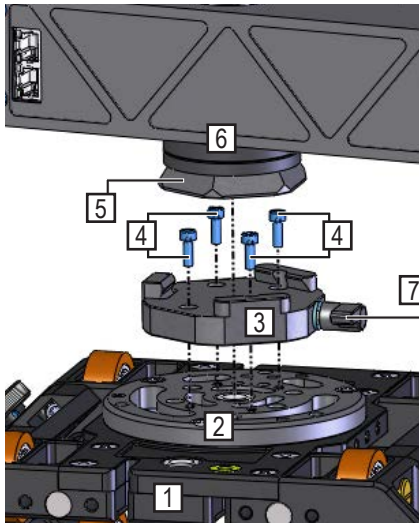

In order to remove the head safely (e.g. for transport) it is enough to loosen the clamp screw and pull out the head together with the plate out of the adapter's base.

TIP

Using the adapter for a fast head mounting is the only solution, which guarantees the reassembly of the head in the same way. It is essential in case of shots, performed with a motion control system, when after disassembly and reassembly of the head we want to reproduce the previously recorded motion of the camera.

4.2. V-mount batteries

Devices of the motion control systems require power supply.

The most reliable solution is mains power supply – the user does not have to worry about the battery level and uses the equipment problem-free. However, such solution has two flaws: it requires cable connection, which sometimes obstructs the usage of the system and does not work while shooting outdoors, where there is no access to the mains power supply.

The most comfortable way of providing stable power supply for the devices is connecting them to standard batteries, used in professional cameras. **SLIDEKAMERA** offers an adapter for mounting batteries, compatible with the V-mount lock.

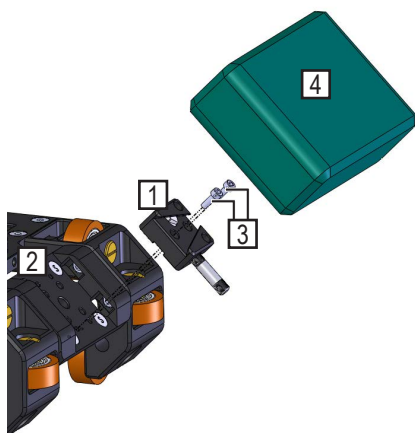

- screw the adapter [1] to the cart's frame [2] with the screws [3], included in the set
- place the V-mount battery [4] in the adapter [1],
- Connect the battery with an appropriate cable (depending on the kind of the battery and the powered device) – in most cases it will be a cable, which connects the battery's D-tap socket and the DC socket of the powered device; appropriate cables and adapters can be found in **SLIDEKAMERA** offer.

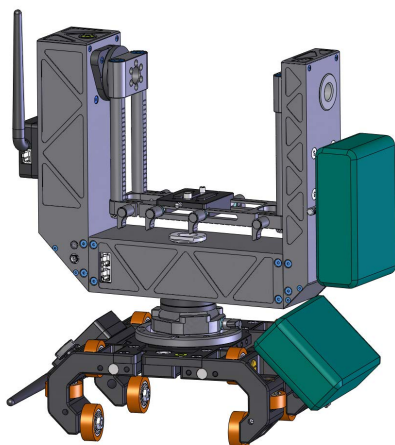

The V-mount battery's adapter can be used not only on the slider's cart. Its universal mounting allows to place the battery e.g. on the remote-controlled heads or on third party devices.

5. Usage of ATLAS MODULAR slider

Before using the ATLAS MODULAR slider:

- put correctly together all elements of the slider (section 3, p. 5),
- check for occurrence of clearances in element connections (section connections, end stops, tripod adapters, etc.),
- secure all cables: the ones, connecting and powering the motion control system's elements, as well as the ones, protecting the camera from accidental breaking or screwing into the gear of the slider and head,
- make sure that the slider is in a stable position and there is no risk of dropping the equipment in the whole range of the slider's dolly motion (it is essential especially in case of using a tripod and a heavy camera);
- if the system is based on several tripods, adjust the height of each so they form a straight line,
- when using one tripod and a very heavy camera an additional **DUAL** support can be used.

TIP

When using the slider upside – down make sure its mount is sufficient enough to hold the weight of all installed devices.

5.1. Manual work

Necessary components:

- ATLAS MODULAR slider of any length
- any manual head for mounting the camera
- any camera (the weight of the head and camera cannot exceed 40kg)



To use the slider in a manual mode:

- mount an appropriate adapter on the slider's cart, depending on the used head (section 3.2, p. 6),
- install the head on the adapter,
- release the park brake [1] before starting work with the slider,
- adjust the settings of the damping brake [2] to the preferences, camera's weight and needs of the given shot.

TIP

When a bigger resistance is set, then it is necessary to use a larger force to move the slider's dolly. In most cases it helps to maintain a fluent motion of the camera, especially when the dolly is starting and stopping.

5.2. Working with ATLAS MODULAR drive

Necessary components:

- **ATLAS MODULAR** slider of any length,
- **ATLAS MODULAR** drive,
- a hardware controller (**AION** or **KAIROS** series), or a tablet with **Slideye PRO** application (connected to the drive by a Wi-Fi **SLIDE LINK** adapter or a wired adapter),
- a power supply (battery or power supply unit),
- any manual head for mounting the camera,
- any camera (the weight of the head and camera cannot exceed 40kg)



NOTE:

The **ATLAS MODULAR** drive was designed for horizontal work (in standard position, as well as upside down). That is why it can reach high speed but it cannot be used on a moving dolly when the slider is slanted or in vertical position.

To use the slider with the drive:

- prepare the slider in the same way as for manual work (section 5.1, p. 11),
- install the **ATLAS MODULAR** drive (section 3.6, p. 8).

The ATLAS MODULAR drive as the only motion of the camera

The manual head can be set in a fixed position and, by only moving the slider's engine, you can achieve an unusually fluent and repetitive shot.

The ATLAS MODULAR drive and the manual work of the head

The **ATLAS MODULAR** head can function as a "digital dolly operator". It can move the slider's dolly in a pre-programmed way. The camera operator can focus on using the manual head, which is mounted on the cart. In contrast to the typical manual work this mode allows to accomplish a more fluent motion, as the operator is not burdened with controlling the movement of the camera in all planes.

TIP

The drive can be controlled in real time by a second person, who can immediately react to changes in the shot. Thanks to this the slider's motion does not have to be pre-programmed.

5.3. The ATLAS MODULAR drive and a controlled head

Necessary components:

- **ATLAS MODULAR** slider of any length,
- **ATLAS MODULAR** drive,
- a **SLIDEKAMERA** controlled head (e.g. **X HEAD** or **BULL HEAD**)
- a hardware controller (**KAIROS** series), or a tablet with **Slideye PRO** application (connected to the drive by a Wi-Fi **SLIDE LINK** adapter or a wired adapter),
- a power supply (battery or power supply unit),
- any camera (the weight of the camera cannot exceed 8kg)



Connection of the **ATLAS MODULAR** slider's drive and the **SLIDEKAMERA** controlled head (**X HEAD** or **BULL HEAD**) allows creating a full motion control system. Thanks to the combination of the slider's drive and the head the user gets an integrated system, which can be controlled with a single controller or the **Slideye PRO** application for mobile devices.

To use the slider with a controlled head:

- fix the mounting disc on the cart's frame (section 3.2, p. 6),
- install the head with a quick release adapter or a 3/8" screw; details of mounting particular heads can be found in their instruction manuals.

NOTE:

The system, set up in this way can be operated **ONLY** with controlling devices (a controller or a Slideye PRO application). Under no circumstances force for moving and rotating devices can be applied – it may damage drives or the gear of the slider and the head!

6. Technical specification

Length of rail:	section 0,8m section 1,2m
Weight:	section 0,8m: 6kg section 1,2m: 8,5kg cart: 3kg
Span of the rail's profiles:	160mm
Maximum width of feet:	400mm
Range of feet adjustment:	20mm
Load capacity:	40kg
Rail's mounting holes:	<ul style="list-style-type: none"> • 3 mounting ports with 3/8" holes • 6 M5 mounting holes for screwing the adapter • 4 pits for M4 Allen screws in Manfrotto distance
Rail ports:	<ul style="list-style-type: none"> • hardened 3/8" thread, enabling mounting the slider directly on tripod • threads for mounting feet for putting the slider on the ground
cart's mounting holes:	<ul style="list-style-type: none"> • 2 3/8" holes in the upper part • 6 1/4" threaded holes on the both sides of the dolly • 8 M6 holes for mounting accessories in the front and back of the dolly • 8 M6 holes on the inner side of the wheel support
cart's central port:	<ul style="list-style-type: none"> • aluminum 75/100mm bowl for a leveling half-ball • A flat plate with a 1/4" or 3/8" and 8 M4 threaded holes in Manfrotto standard for mounting adapters
cart's level:	1 piece on device's cart
rail's level:	1 piece per rail's section
material:	black anodized aluminum

7. Terms of warranty

All Slidekamera products are covered by the manufacturer's warranty for a period of 12 months from the date of sale. Warranty covers production faults and material defects, which resulted in the product malfunctioning. Warranty covers the repair, or, if the repair proves impossible, replacement of the product with a new one. However, the cost of repair of the product cannot overrun the catalogue value of the product. The warranty does not cover damage and / or product defects resulting from the improper usage, as well as not following product maintenance specifications.

The warranty excludes:

- unauthorized attempts to repair or modify
- mechanical damage caused during transport and operation of such features as scratches, dents, pits, dirt, etc.
- flooding, moisture

To obtain warranty service the purchaser should deliver the damaged product together with a proof of purchase or proof of payment (invoice, cash register receipt). The product will be accepted for warranty service on condition, that it is delivered with correctly filled in complaint form and properly protected during transport.

The complaint form is available for download at: www.slidekamera.com.

After the warranty period is exceeded any spare parts can be purchased directly from the manufacturer or in any selected points of sale.

PLEASE NOTE:

Any package sent at the expense of HET-CNC s.c., 80-175 Gdańsk, ul. Kartuska 386 will not be received.

SLIDEKAMERA

NEXT LEVEL OF FILMMAKING

